



ILLUSTRATED PARTS BOOK

196cc Rear Tine Tiller

PRTT196E.1

PRTT196E.2



# Table of Contents

Upper Handle Assembly.....	2
Forward Controls.....	3-4
Rear Controls.....	5-6
Tines & Tine Shield.....	7
Transmission.....	8-11
Unit Decals.....	12
Engine Sub-Assemblies:	
Cylinder Head.....	13
Crankcase.....	14
Crankcase Cover.....	15
Camshaft.....	16
Recoil Starter.....	17
Carburetor.....	18
Flywheel / Ignition.....	19
Air Filter.....	20
Control Assembly.....	21
Muffler.....	22
Fuel Tank - EPA3.....	23
Engine Decals.....	24

# Upper Handle Assembly

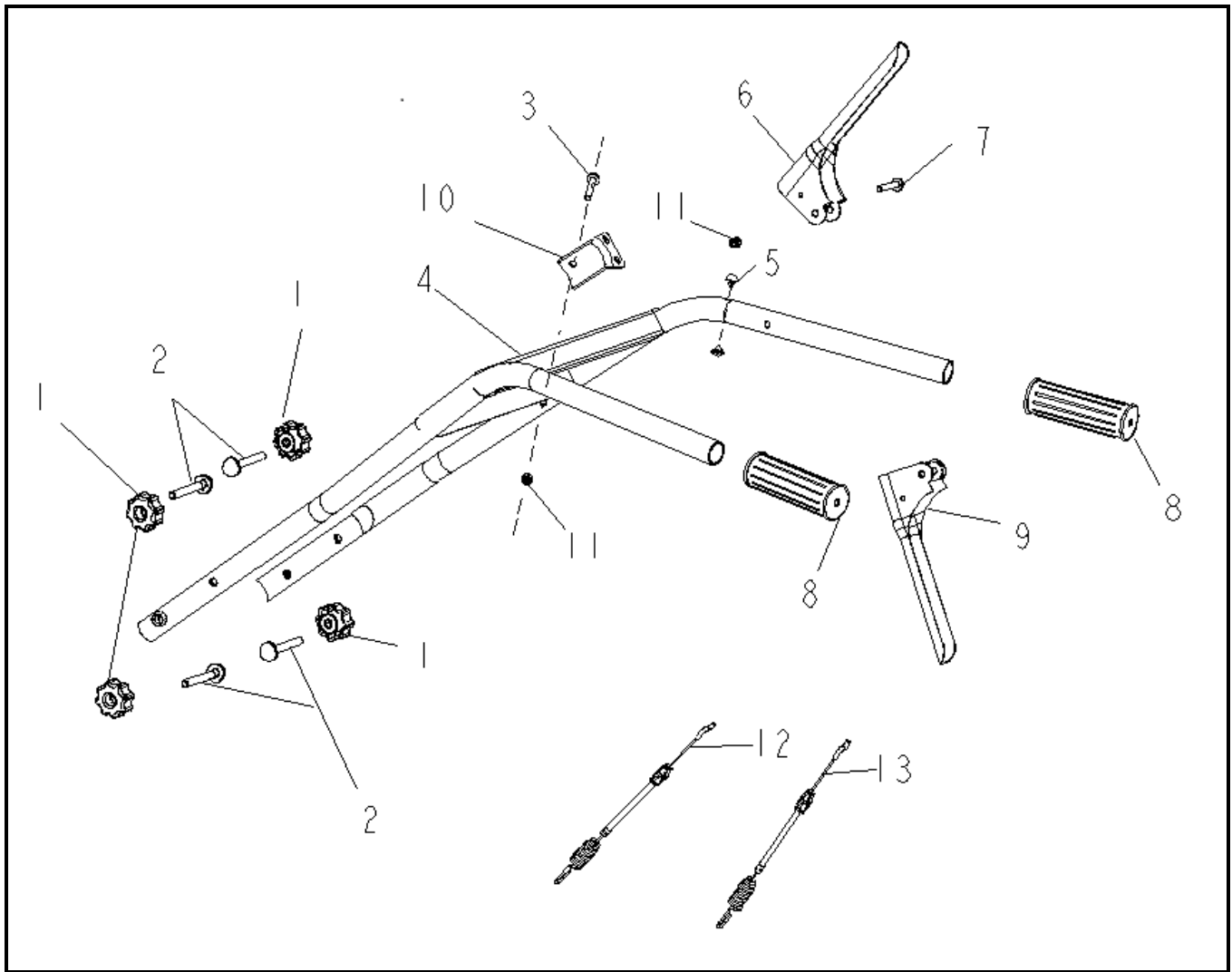

REF. NO.	DESCRIPTION	PART NO.	QTY
1	Knob, Handle	A200486	4
2	Screw, M8 x 1.25 x 50, Carriage	A202629	4
3	Screw, M6 x 1.0 x 40, HFH, Grade 8.8, Zinc	<i>Reference Only</i>	1
4	Handle, Upper	A203116	1
5	Bushing, Rubber Clutch Lever	A200490	2
6	Lever, Forward Clutch	A203118	1
7	Screw, M6 x 1.0 x 45, HFH, Grade 8.8, Zinc	<i>Reference Only</i>	1
8	Grip, Handle	A200802	2
9	Lever, Reverse Clutch	A203119	1
10	Bracket, Clutch Cable Handle Mounting	A203117	1
11	Locknut, M6 x 1.0, Nylon Insert, Grade 8, Zinc	<i>Reference Only</i>	2
12	Cable, Forward Extension Control (1440mm)	A203120	1
13	Cable, Reverse Extension Control (1430mm)	A203121	1

# Forward Controls

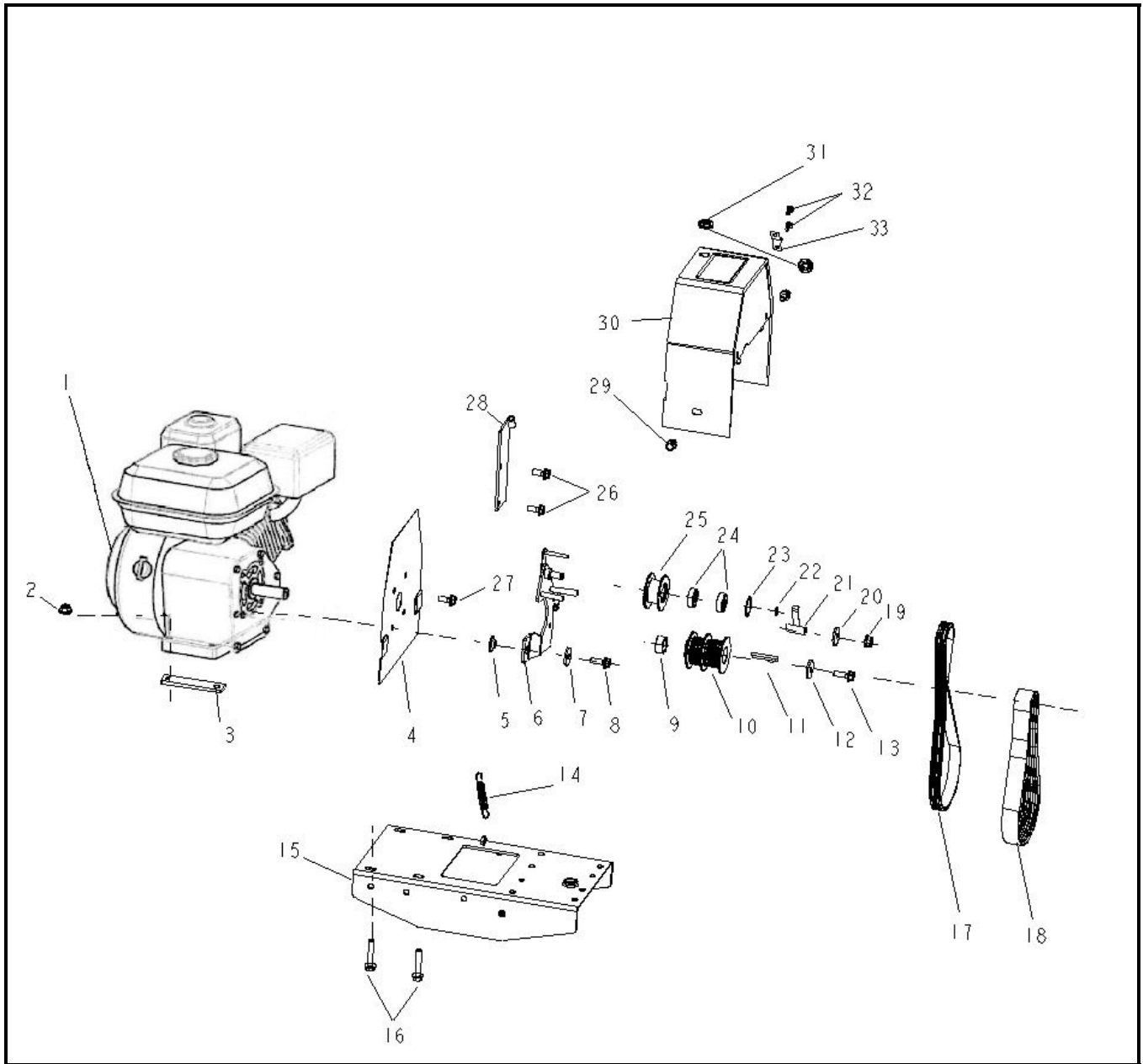

## Forward Controls (continued)

REF. NO.	DESCRIPTION	PART NO.	QTY
1	Engine, 196cc EPA Phase 3	A202402	1
2	Nut, M8 x 1.25, Hex, Grade 8, Zinc	<i>Reference Only</i>	8
3	Spacer, Engine Mounting	A200534	2
4	Plate, Belt Cover Mounting, Powermate Orange	A200505	1
5	Spacer, PM Bracket	A200542	1
6	Bracket, Reverse Tensioner	A203122	1
7	Flat Washer, 8.5 x 22.2 x 3mm	A203135	1
8	Screw, M8 x 1.25 x 25, Hex Head, Grade 8.8, Zinc	<i>Reference Only</i>	1
9	Bushing, Forward Pulley Shaft	A200509	1
10	Pulley, Forward Drive	A200510	1
11	Key, 4.78 x 5 x 45	A200511	1
12	Flat Washer, 8.5 x 24.5 x 4mm	A200513	1
13	Screw, 5/16-24 x 25, HFH, Grade 8.8, Zinc	<i>Reference Only</i>	1
14	Spring, Tension	A200544	1
15	Frame, Engine Mounting, Powermate Orange	A200536	1
16	Screw, M8 x 1.25 x 40, Hex, Grade 8.8, Zinc	<i>Reference Only</i>	4
17	Belt, Reverse Drive, 5PK740	A200528	1
18	Belt, Reverse Drive, 7PK597	A200512	1
19	Nut, M8 x 1.25, Hex Flange	<i>Reference Only</i>	1
20	Flat Washer, M8	<i>Reference Only</i>	1
21	Guide, Belt	A203136	1
22	Circlip, 10	<i>Reference Only</i>	1
23	Circlip, 30	<i>Reference Only</i>	1
24	Bearing, 6200-2RZ	<i>Reference Only</i>	2
25	Pulley, Reverse Tensioner	A200527	1
26	Screw Assembly, M8 x 1.25 x 16, Hex Head	<i>Reference Only</i>	2
27	Screw Assembly, M8 x 1.0 x 16, Hex Head	<i>Reference Only</i>	5
28	Plate, Reverse Cable Belt Mounting	A203123	1
29	Screw, M8 x 1.25 x 16, Hex Head, Grade 8.8, Zinc	<i>Reference Only</i>	2
30	Cover, Belt, Powermate Orange	A203124	1
31	Grommet, Belt Cover Rubber	A200569	2
32	Screw, 4.2 x 9.5	<i>Reference Only</i>	2
33	Fastener, Cable	A203138	1

# Rear Controls

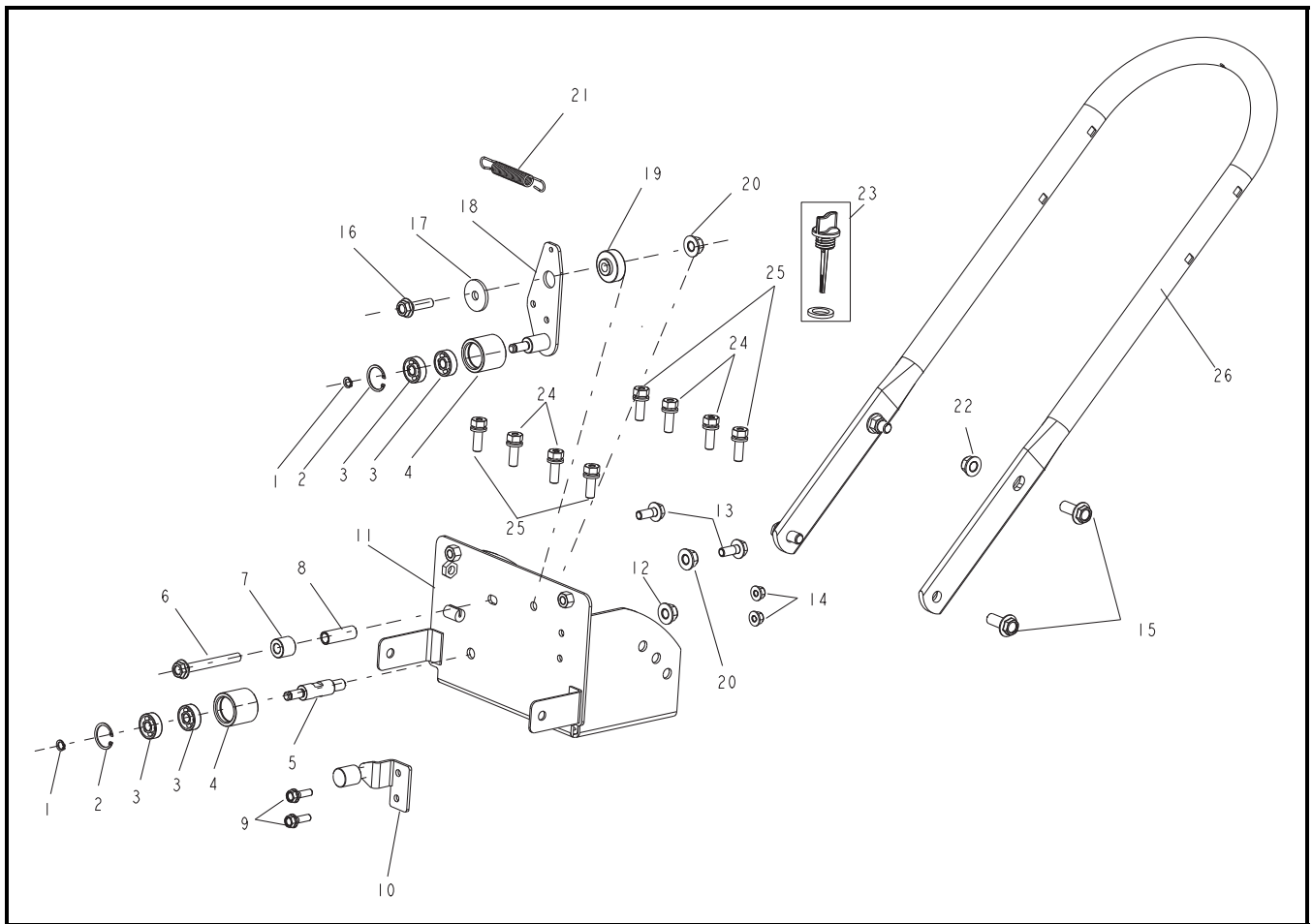

## Rear Controls (continued)

REF. NO.	DESCRIPTION	PART NO.	QTY
1	Circlip, 8	A200547	2
2	Circlip, 24	<i>Reference Only</i>	2
3	Bearing, 628-2RZ	<i>Reference Only</i>	4
4	Pulley, Forward Tensioner	A200549	2
5	Shaft, Forward Tensioner	A200559	1
6	Screw, M8 x 1.25 x 65, Hex Head, Grade 8.8, Zinc	<i>Reference Only</i>	1
7	Bushing, 2	A200558	1
8	Bushing, 3	A200560	1
9	Screw, M6 x 1.0 x 20, Hex Head, Grade 8.8, Zinc	<i>Reference Only</i>	2
10	Guide, Reverse Belt	A200557	1
11	Frame, Handle Mounting, Powermate Orange	A203127	1
12	Nut, M10 x 1.5, Hex Flange	<i>Reference Only</i>	1
13	Screw, M8 x 1.25 x 16, Hex Head, Grade 8.8, Zinc	<i>Reference Only</i>	2
14	Nut, M6 x 1.0, Hex	<i>Reference Only</i>	2
15	Screw, M10 x 1.5 x 25, Hex Head, Grade 8.8, Zinc	<i>Reference Only</i>	4
16	Screw, M8 x 1.25 x 30, Hex Head, Grade 8.8, Zinc	<i>Reference Only</i>	1
17	Flange Washer, 8.5 x 30 x 3mm, Zinc	A200513	1
18	Arm, Clutch Bracket	A203129	1
19	Bushing, Shaft Tensioner	A200552	1
20	Nut, M8 x 1.25, Hex Flange	<i>Reference Only</i>	1
21	Spring, Tension	A200544	1
22	Nut, M10 x 1.5, Hex, Grade 8, Zinc	<i>Reference Only</i>	2
23	Assembly, Dipstick	A203137	1
24	Screw Assembly, M8 x 1.25 x 25, Hex Head	<i>Reference Only</i>	9
25	Screw Assembly, M8 x 1.25 x 20, Hex Head	<i>Reference Only</i>	10
26	Handle, Lower	A202636	1

# Tines & Tine Shield

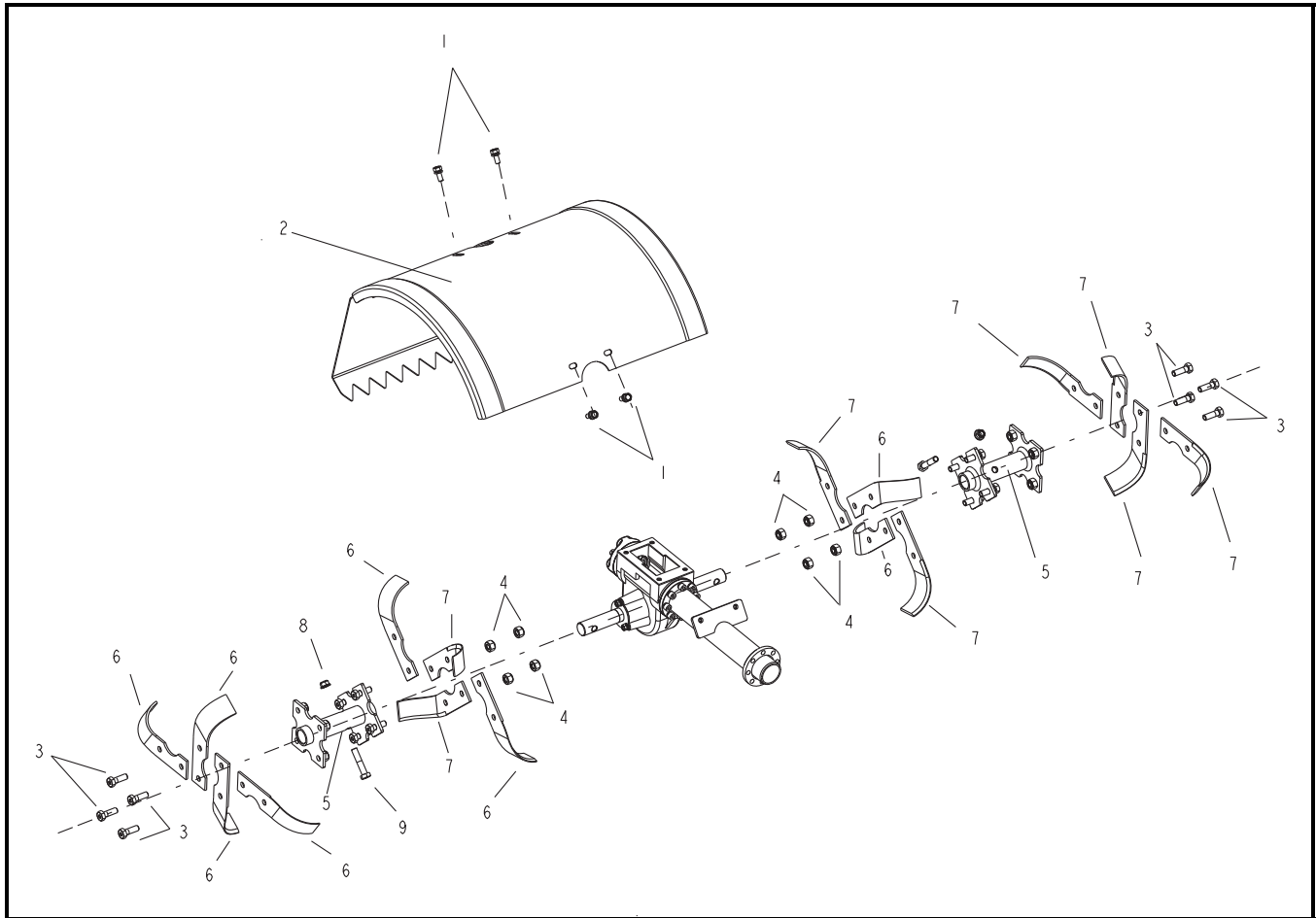

REF. NO.	DESCRIPTION	PART NO.	QTY
1	Screw, M8 x 1.25 x 20, Hex Head, Grade 8.8, Zinc	<i>Reference Only</i>	4
2	Shield, Main Tine, Powermate Orange	A200572	1
3	Screw, M8 x 1.25 x 25, Hex Head	<i>Reference Only</i>	16
4	Nut, M8 x 1.25, Hex, Nylon Insert	<i>Reference Only</i>	16
5	Hub, Tine	A203130	2
6	Tines, Right	A202957	8
7	Tines, Left	A202956	8
8	Nut, M10 x 1.5, Hex	<i>Reference Only</i>	2
9	Screw, M10 x 1.5 x 50, Hex Head	<i>Reference Only</i>	2



# Transmission (for PRTT196E.1)

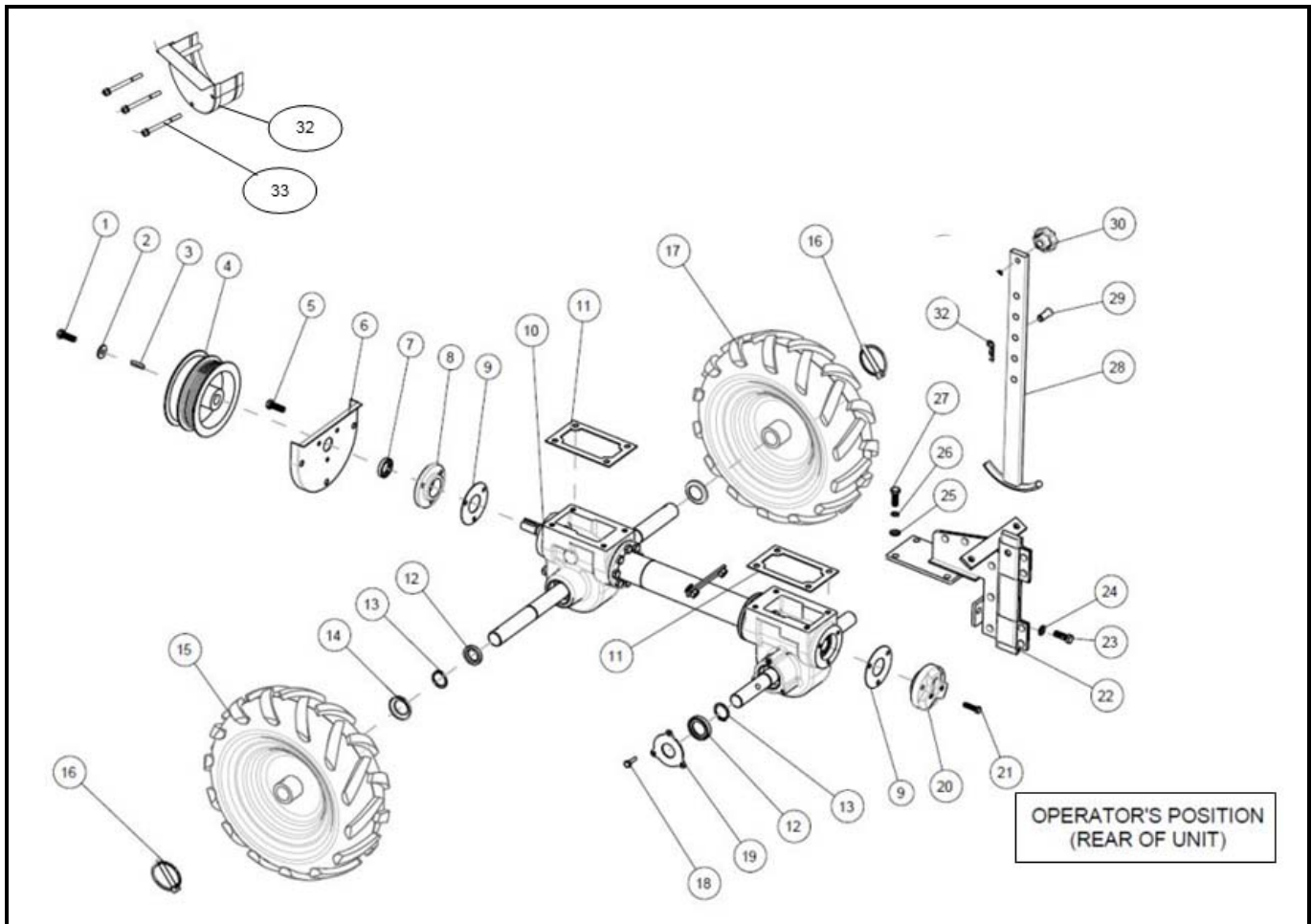

## Transmission (for PRTT196E.1 continued)

REF. NO.	DESCRIPTION	PART NO.	QTY
1	Screw, M8 x 1.25 x 25, Hex Head, Grade 8.8, Zinc	<i>Reference Only</i>	1
2	Flat Washer, M8, Zinc	<i>Reference Only</i>	1
3	Key, 5 x 5 x 25	A200586	1
4	Pulley, Transmission	A200587	1
5	Screw, M6 x 1.0 x 25, Hex Head, Grade 8.8, Zinc	<i>Reference Only</i>	3
6	Cover, Lower Stationary Belt, Powermate Orange	A200589	1
7	Seal, Transmission Oil, 19 x 32 x 7	A200591	1
8	Cover, Front Transmission	<i>Reference Only</i>	1
9	Gasket, Transmission	A200592	2
10	Kit, Transmission Assembly	A201911	1
11	Gasket, Transmission Gearbox	A200538	2
12	Seal, Transmission Oil, 25 x 40 x 7	A200601	4
13	C-Clip, 25	A200599	4
14	Spacer, Wheel Shaft	A200598	2
15	Tire, 13" Left (Determined from Operator's Position)	A200597	1
16	Pin, Wheel Lock	A200596	2
17	Tire, 13" Right (Determined from Operator's Position)	A200809	1
18	Screw, M6 x 1.0 x 25, Hex Head, Grade 8.8, Zinc	<i>Reference Only</i>	12
19	Cap, Transmission Seal	A200607	4
20	Cover, Transmission Rear	A200613	1
21	Screw, M6 x 1.0 x 25, Hex Head, Grade 8.8, Zinc	<i>Reference Only</i>	3
22	Frame, Drag Bar Mounting	A200574	1
23	Screw, M8 x 1.25 x 20, Hex Head, Grade 8.8, Zinc	<i>Reference Only</i>	2
24	Flat Washer, M8, Zinc	<i>Reference Only</i>	2
25	Flat Washer, M8, Zinc	<i>Reference Only</i>	4
26	Lock Washer, M8, Zinc	<i>Reference Only</i>	4
27	Screw, M8 x 1.25 x 25, Hex Head, Grade 8.8, Zinc	<i>Reference Only</i>	4
28	Bar, Drag	A200576	1
29	Pin, Drag Bar	A200577	1
30	Knob, Drag Bar Handle	A200575	1
31	Screw, M8 x 1.25 x 30, Hex Head, Grade 8.8, Zinc	<i>Reference Only</i>	1
32	Cover, Lower Front Belt, Powermate Orange	A200584	1
33	Screw, M8 x 1.25 x 90, Hex Head, Grade 8.8, Zinc	A200583	3

# Transmission (for PRTT196E.2)

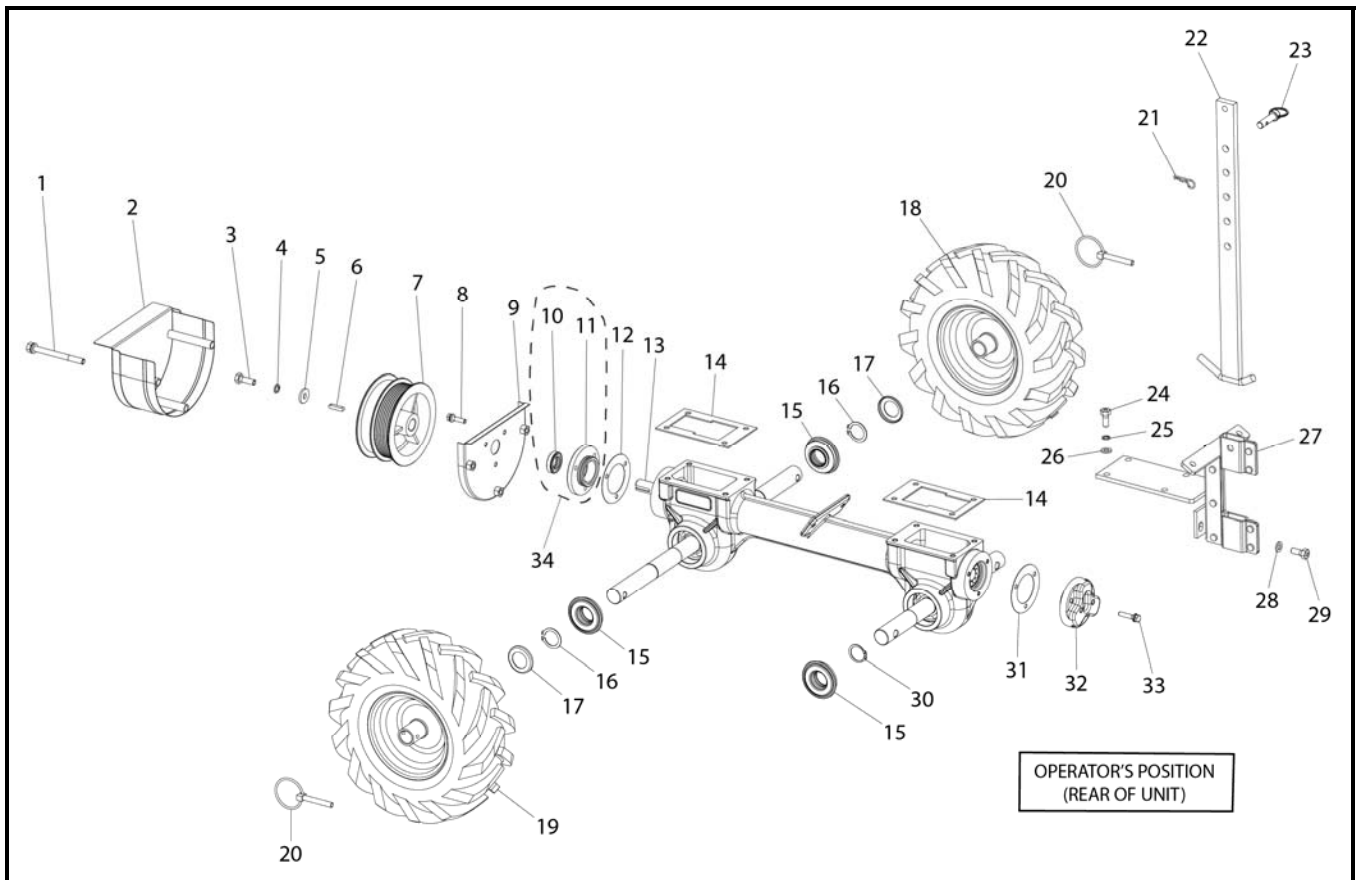

## Transmission (for PRTT196E.2 continued)

REF. NO.	DESCRIPTION	PART NO.	QTY
1	Screw, M8 x 1.25 x 90, Hex Head, Grade 8.8, Zinc	A200583	3
2	Cover, Lower Front Belt, Powermate Orange	A200584	1
3	Screw, M8 x 1.25 x 25, Hex Head, Grade 8.8, Zinc	<i>Reference Only</i>	1
4	Lock Washer, M8, Zinc	<i>Reference Only</i>	1
5	Flat Washer, M8, Zinc	<i>Reference Only</i>	1
6	Key, 5 x 5 x 25	A200586	1
7	Pulley, Transmission	A200587	1
8	Screw, M6 x 1.0 x 25, Hex Head, Grade 8.8, Zinc	<i>Reference Only</i>	3
9	Cover, Lower Stationary Belt, Powermate Orange	A200589	1
10	Seal, Transmission Oil, 20 x 37 x 7	<i>Reference Only</i>	1
11	Cover, Front Transmission	<i>Reference Only</i>	1
12	Gasket, Transmission	A203887	2
13	Kit, Transmission Assembly	A203888	1
14	Gasket, Transmission Gearbox	A200538	2
15	Seal, Transmission Oil	A203889	4
16	C-Clip, 25	A200599	2
17	Spacer, Wheel Shaft	A200598	2
18	Tire, 13" Right (Determined from Operator's Position)	A200809	1
19	Tire, 13" Left (Determined from Operator's Position)	A200597	1
20	Pin, Wheel Lock	A200596	2
21	Pin, Cotter	<i>Reference Only</i>	1
22	Bar, Drag	A200576	1
23	Pin, Drag Bar	A200577	1
24	Screw, M8 x 1.25 x 25, Hex Head, Grade 8.8, Zinc	<i>Reference Only</i>	4
25	Lock Washer, M8, Zinc	<i>Reference Only</i>	4
26	Flat Washer, M8, Zinc	<i>Reference Only</i>	4
27	Frame, Drag Bar Mounting	A200574	1
28	Flat Washer, M8, Zinc	<i>Reference Only</i>	2
29	Screw, M8 x 1.25 x 20, Hex Head, Grade 8.8, Zinc	<i>Reference Only</i>	2
30	C-Clip, 24	A203891	2
31	Gasket, Transmission	A200592	2
32	Cover, Transmission Rear	A203890	1
33	Screw, M6 x 1.0 x 25, Hex Head, Grade 8.8, Zinc	<i>Reference Only</i>	3
34	Kit, Transmission Front Cover with Seal	A203886	1

# Unit Decals

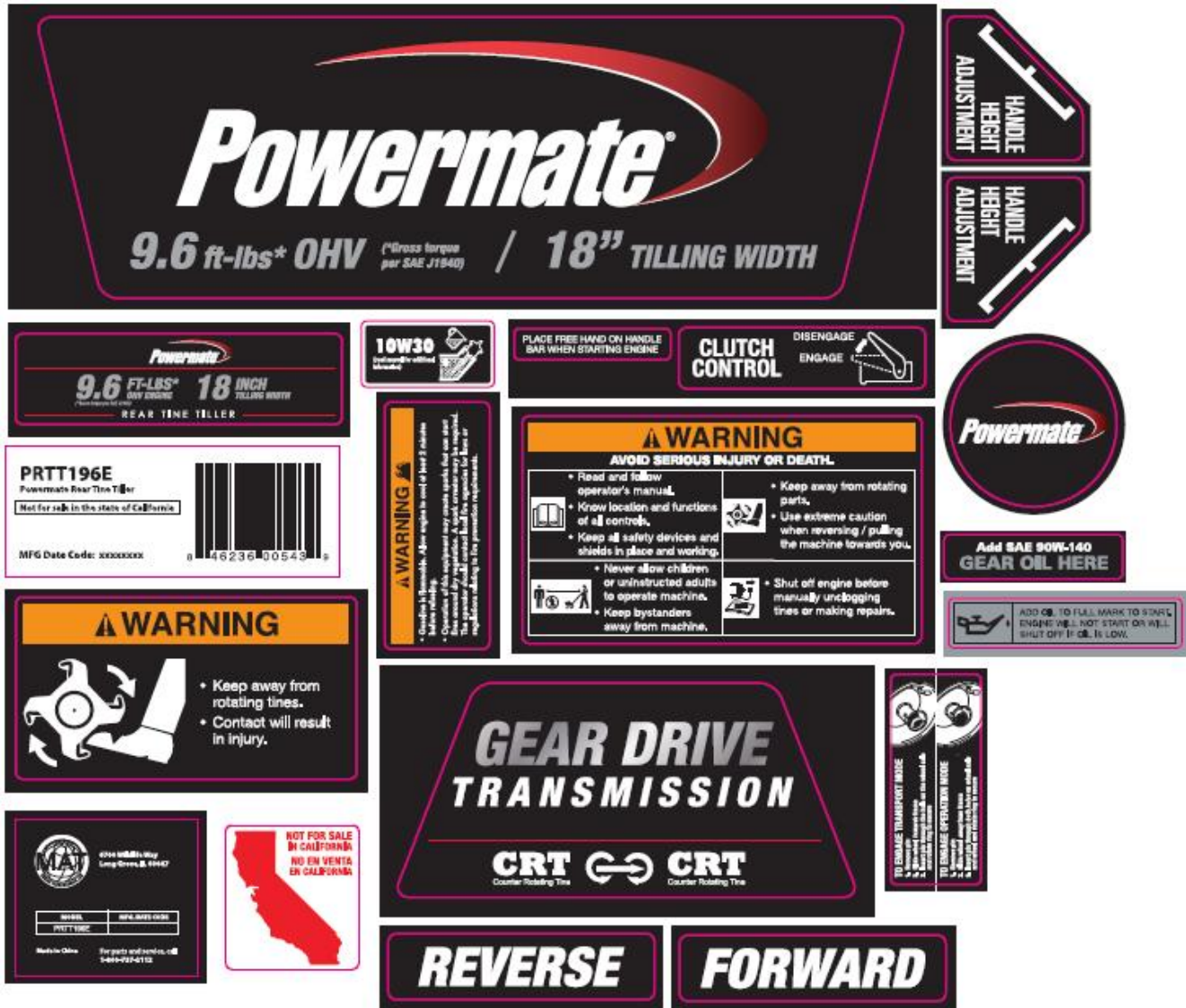

REF. NO.	DESCRIPTION	PART NO.	QTY
1	Decal Sheet, PRTT196E	A202637	1

# Cylinder Head

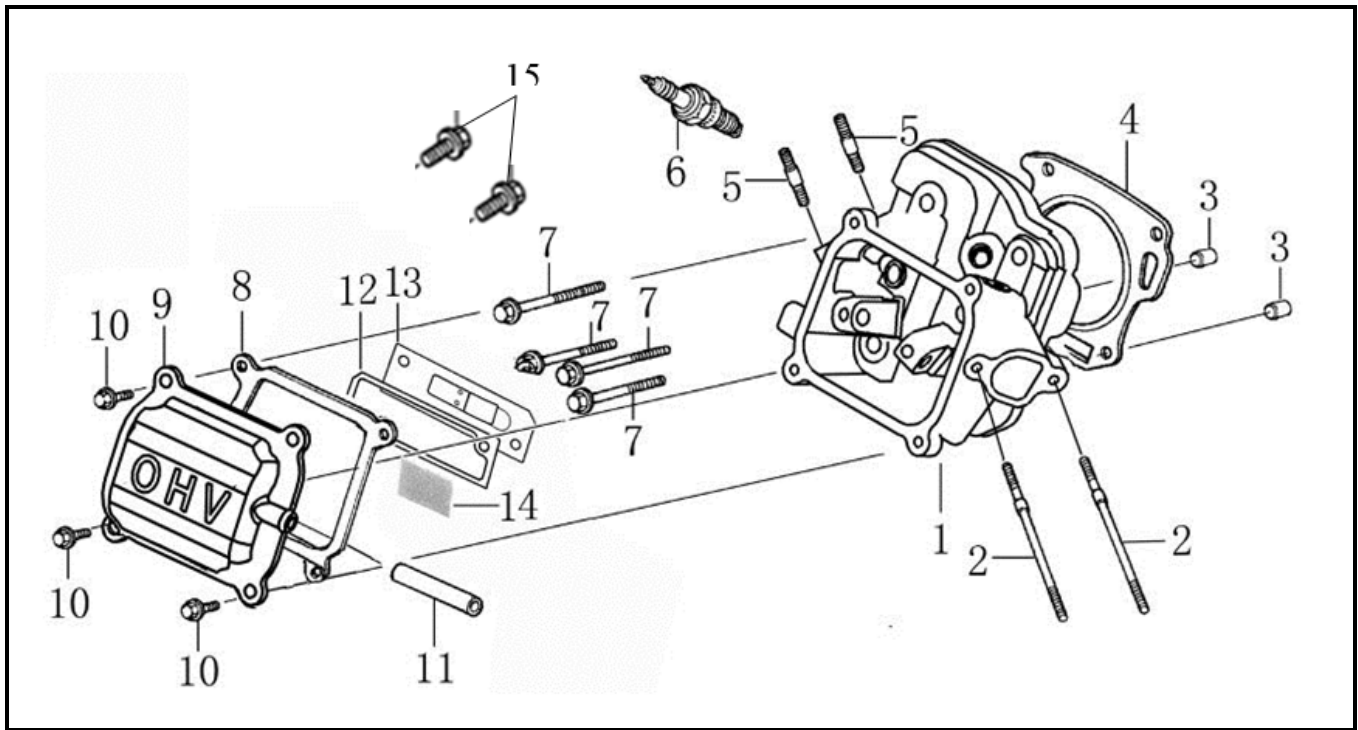

REF. NO.	DESCRIPTION	PART NO.	QTY
1	Head, Cylinder – EPA3	<i>Reference Only</i>	1
2	Stud, Threaded, 1	<i>Reference Only</i>	2
3	Pin, Dowel	<i>Reference Only</i>	2
4	Gasket, Cylinder	A201410	1
5	Stud, Threaded, 2	<i>Reference Only</i>	2
6	Plug, Spark, F7TC	A201233	1
7	Screw, M8 x 1.25 x 60, HFH, Grade 8.8, Zinc	<i>Reference Only</i>	4
8	Gasket, Valve Cover – EPA3	A202638	1
9	Cover, Valve – EPA3	A202639	1
10	Screw, M6 x 1.0 x 14, HFH, Grade 8.8, Zinc	<i>Reference Only</i>	4
11	Tube, Breather	A201416	1
12	Cap, Breather Chamber Ga	A202640	1
13	Gasket, Breather Chamber St	A202641	1
14	Strainer, Oil	A202642	1
15	Screw, M5 x 0.8 x 10, HFH, Grade 8.8, Zinc	<i>Reference Only</i>	2

# Crankcase

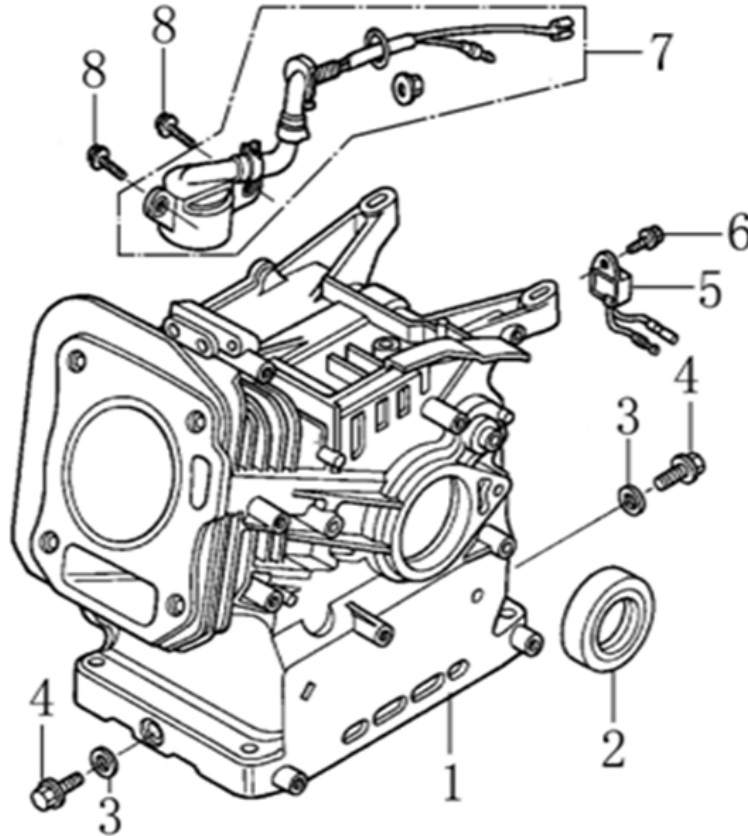

REF. NO.	DESCRIPTION	PART NO.	QTY
1	Crankcase	<i>Reference Only</i>	1
2	Seal, Oil, 25 x 41.25 x 6	A201418	1
3	Washer, Drain Plug	A201419	2
4	Screw, Drain Plug	A201420	2
5	Sensor, Low Oil	A201421	1
6	Screw, M6 x 1.0 x 10, HFH, Grade 8.8, Zinc	<i>Reference Only</i>	1
7	Assembly, Oil Level Switch	A201423	1
8	Screw, M6 x 1.0 x 14, HFH	<i>Reference Only</i>	2

# Crankcase Cover

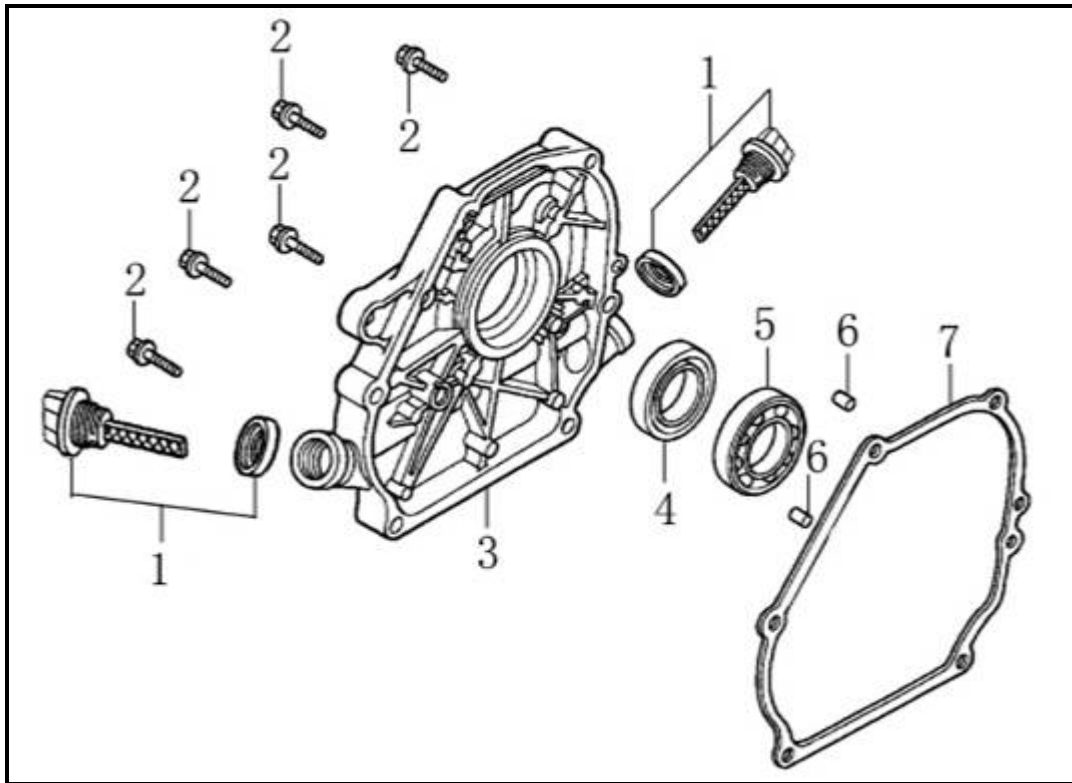

REF. NO.	DESCRIPTION	PART NO.	QTY
1	Kit, Dip Stick	A201430	2
2	Screw, M8 x 1.25 x 32, HFH, Grade 8.8, Zinc	<i>Reference Only</i>	6
3	Cover, Crankcase	<i>Reference Only</i>	1
4	Seal, Oil, 25 x 41.25 x 6	A201418	1
5	Bearing, Radial Ball, 6205	<i>Reference Only</i>	1
6	Pin, Dowel, M8 x 14	<i>Reference Only</i>	2
7	Gasket, Crankcase Cover	A202644	1



# Camshaft

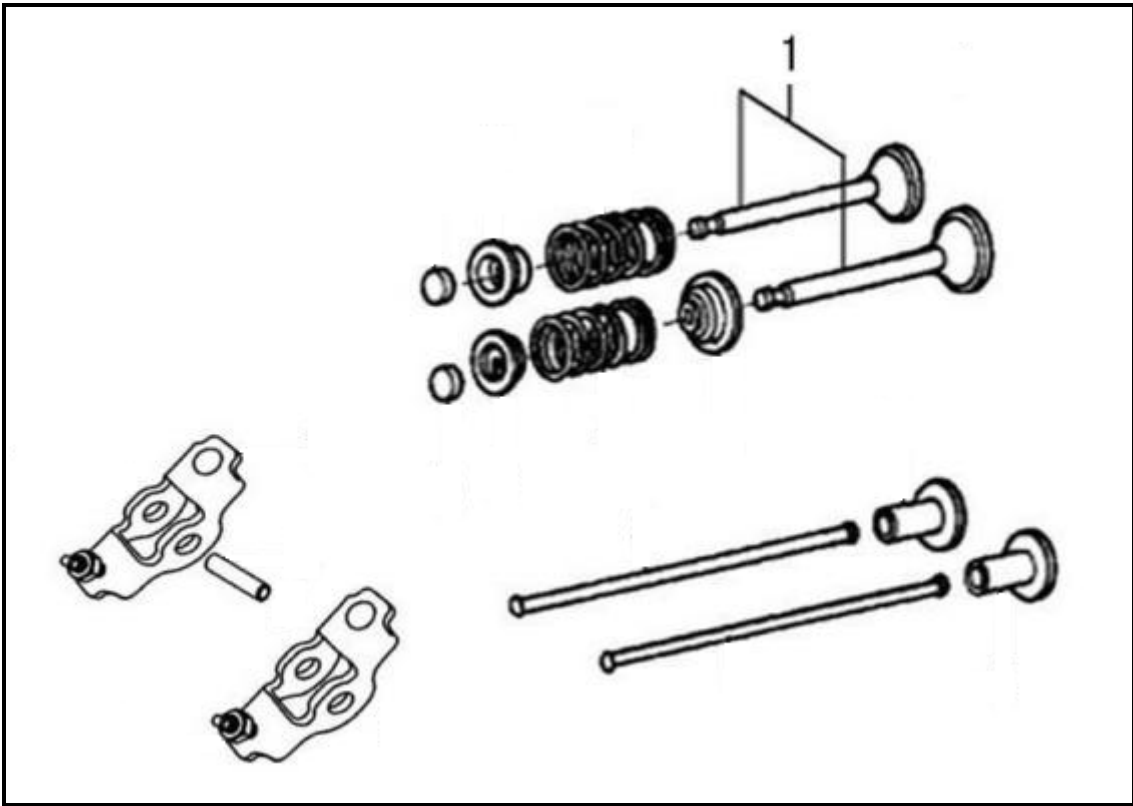

REF. NO.	DESCRIPTION	PART NO.	QTY
1	Kit, Valve Set	A201468	1

# Recoil Starter

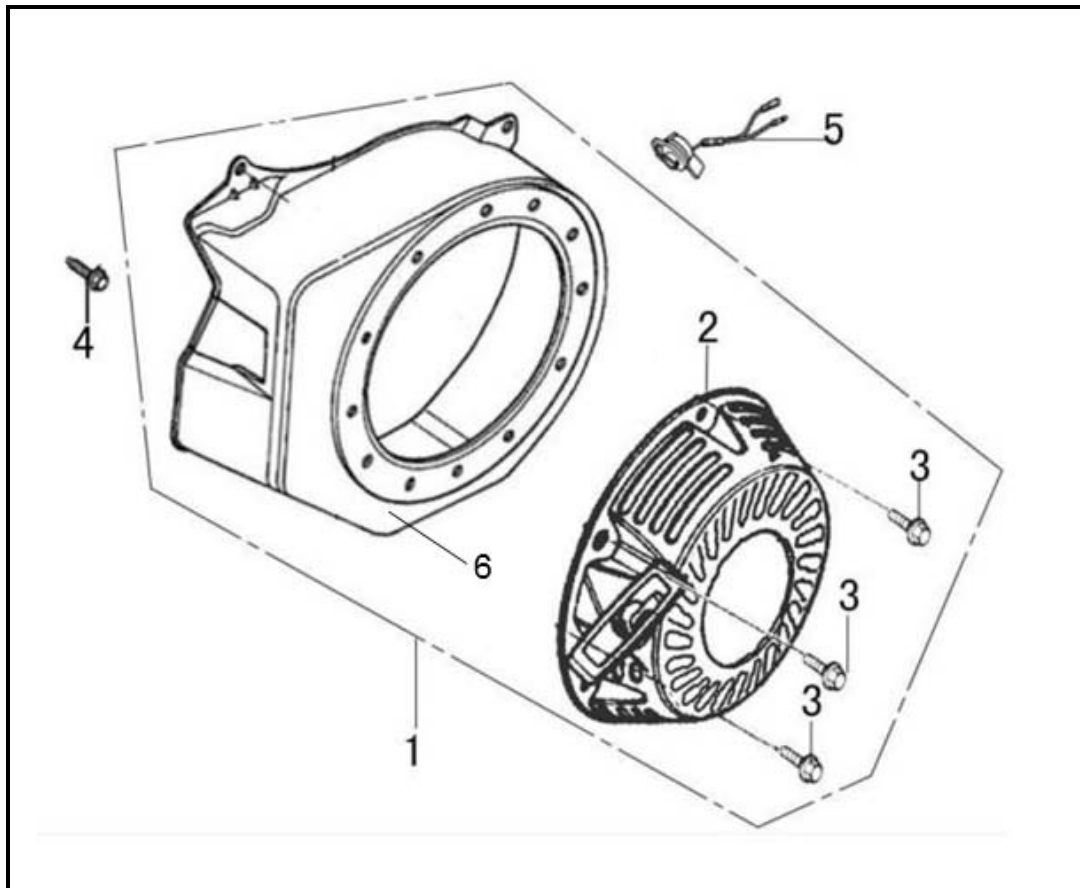

REF. NO.	DESCRIPTION	PART NO.	QTY
1	Kit, Recoil Starter (Includes Items #2, 3, & 6)	A201471	1
2	Kit, Starter Assembly	A201477	1
3	Screw, M6 x 1.0 x 8, HFH, Grade 8.8, Zinc	<i>Reference Only</i>	3
4	Screw, M6 x 1.0 x 10, HFH, Grade 8.8, Zinc	<i>Reference Only</i>	1
5	Assembly, On/Off Switch	A201473	1
6	Cover, Fan	A201474	1

# Carburetor

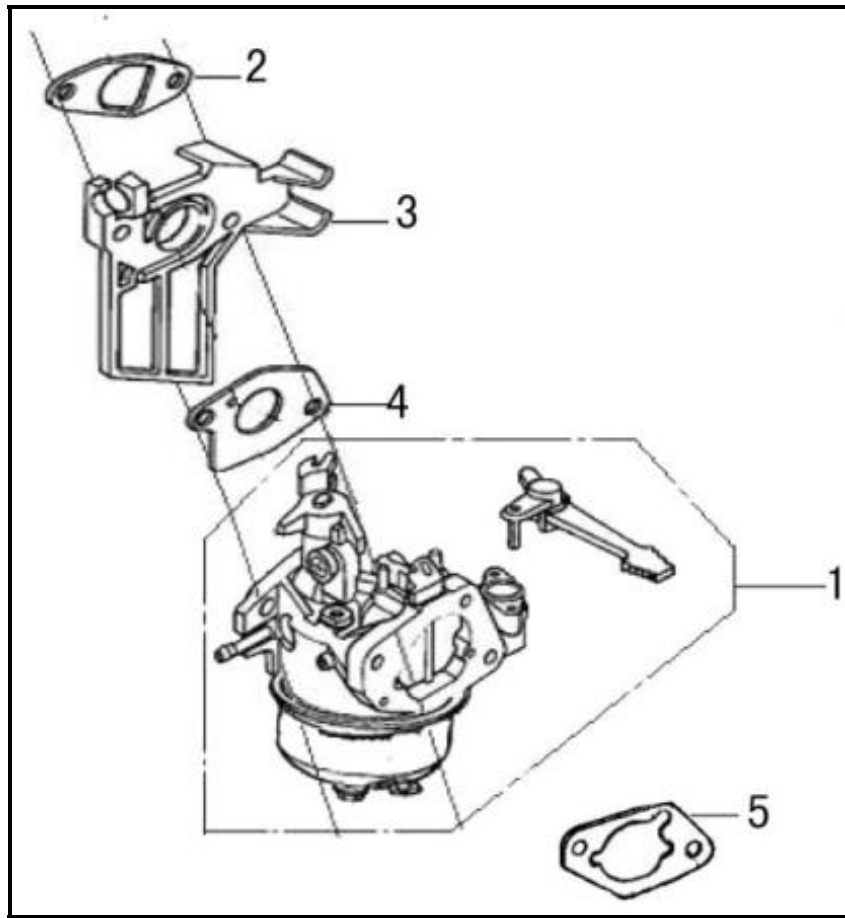

REF. NO.	DESCRIPTION	PART NO.	QTY
1	Assembly, Carburetor – EPA3	A202645	1
2	Gasket, Carburetor Spacer	A202646	1
3	Spacer, Gasket	A201496	1
4	Gasket, Carburetor	A202647	1
5	Gasket, Air Filter	A201498	1
-	Jet, High Altitude (above 7000 feet MSL)	A203104	1

# Flywheel / Ignition

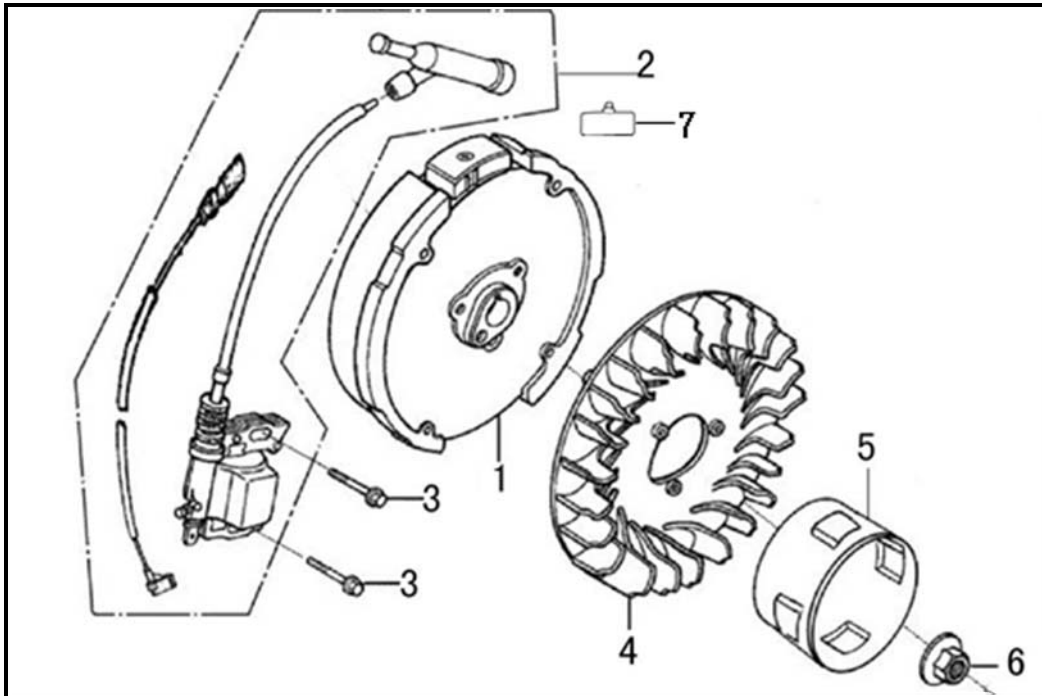

REF. NO.	DESCRIPTION	PART NO.	QTY
1	Assembly, Flywheel	A201512	1
2	Assembly, Ignition Coil	A201513	1
3	Screw, M6 x 1.0 x 25, HFH, Grade 8.8, Zinc	<i>Reference Only</i>	2
4	Fan, Flywheel	A201521	1
5	Pulley, Starter	A201522	1
6	Nut, Flywheel	A201523	1

# Air Cleaner

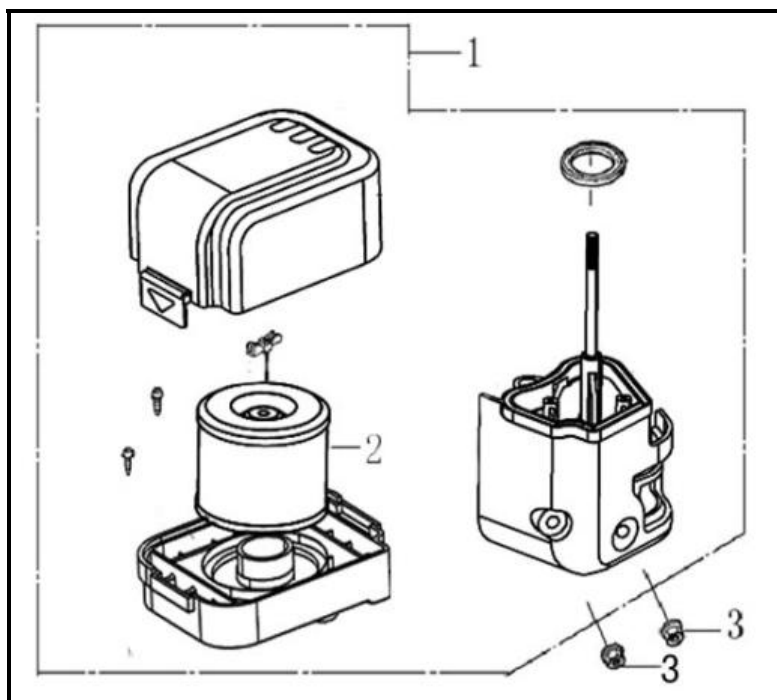

REF. NO.	DESCRIPTION	PART NO.	QTY
1	Kit, Air Filter Assembly – EPA3 (Includes Item #2)	A202648	1
2	Element, Filter – EPA3	A202649	1
3	Nut, M6 x 1.0, Hex Flange, Grade 8, Zinc	<i>Reference Only</i>	2

# Control Assembly

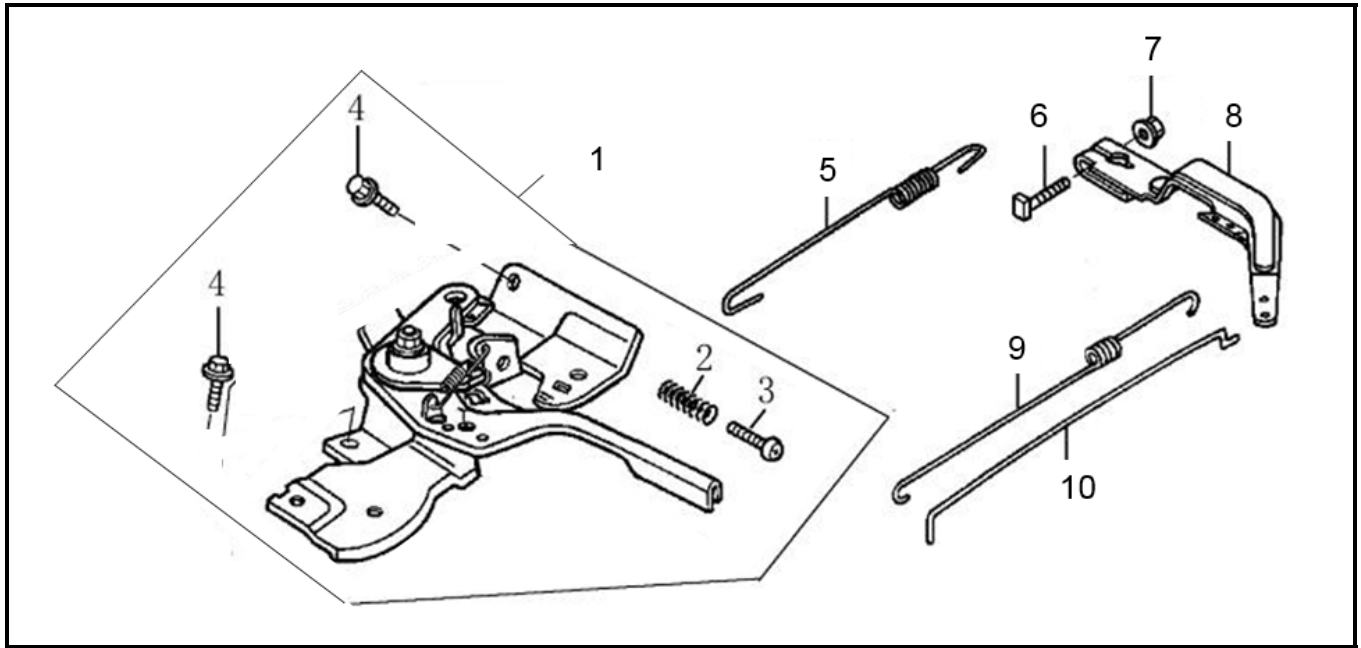

REF. NO.	DESCRIPTION	PART NO.	QTY
1	Kit, Control Assembly (Includes Items #2-4)	A201537	1
2	Spring, Idle	<i>Reference Only</i>	1
3	Screw, M5 x 0.8 x 35	<i>Reference Only</i>	1
4	Bolt, Flange	<i>Reference Only</i>	2
5	Spring, Governor	A201546	1
6	Bolt, Governor Arm	A201547	1
7	Nut, M6 x 1.0, Hex Flange, Grade 8, Zinc	<i>Reference Only</i>	1
8	Arm, Governor	A201549	1
9	Spring, Throttle Return	A201550	1
10	Rod, Governor	A201551	1

# Muffler

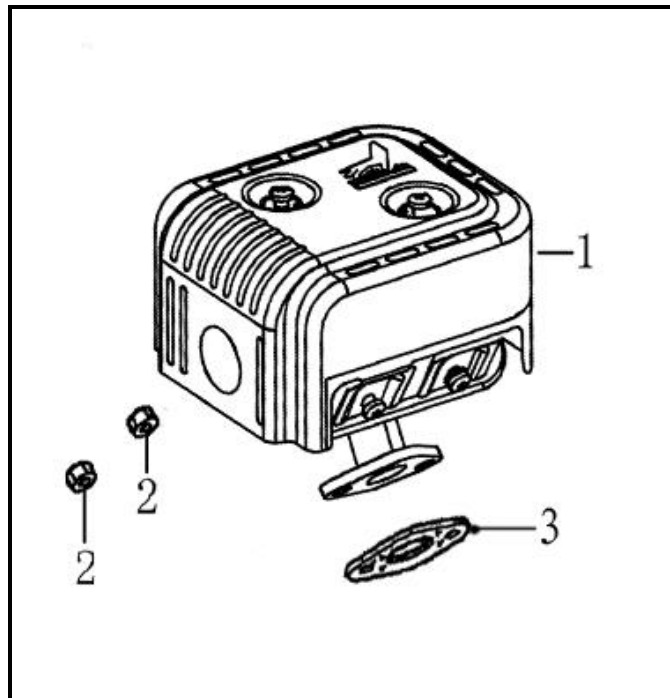

REF. NO.	DESCRIPTION	PART NO.	QTY
1	Assembly, Muffler – EPA3	202650	1
2	Nut, M8 x 1.25, Hex, Grade 8, Zinc	<i>Reference Only</i>	2
3	Gasket, Muffler – EPA3	A202651	1

# Fuel Tank - EPA3

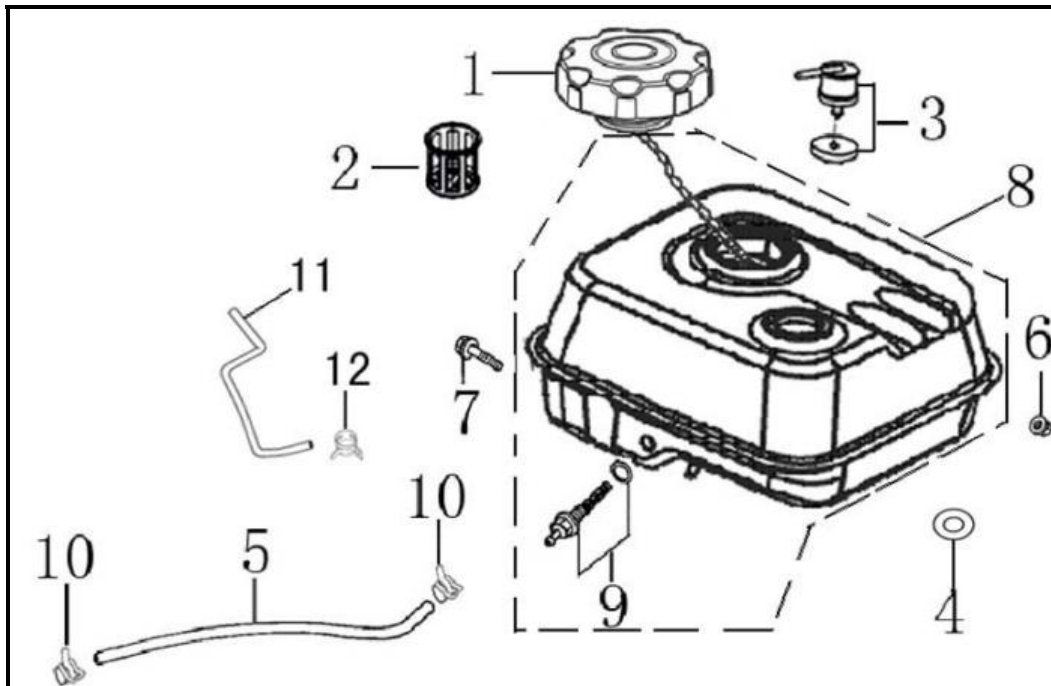



REF. NO.	DESCRIPTION	PART NO.	QTY
1	Cap, Fuel	A202652	1
2	Filter, Fuel Cap	A202653	1
3	Valve, Breather	A202654	1
4	Isolator, Tank	A201563	2
5	Line, Fuel	A202655	1
6	Nut, M6 x 1.0, Hex Flange, Grade 8, Zinc	Reference Only	2
7	Screw, M6 x 1.0 x 25, HFH, Grade 8.8, Zinc	Reference Only	1
8	Tank, Fuel	A202657	1
9	Filter, In-Line Fuel	A201559	1
10	Clip, Fuel Line	Reference Only	2
11	Line, Breather Valve	A202656	1
12	Clip, Breather Valve Line	Reference Only	2



# Engine Decals

⚠ WARNING

	Read and follow Operating Instructions before running engine.
	Gasoline is flammable. Allow engine to cool at least 2 minutes before refueling.
	Engines emit carbon monoxide, DO NOT run in enclosed area.

Use Regular Unleaded Gasoline with a Minimum of 87 Octane

Do Not Use E85 or Fuel Containing More than 10% Ethanol



ENGINE  
START-UP  
INSTRUCTIONS

1. Insert the locking pin to secure the wheels in locked position.
2. Turn the Engine Switch to the "on" position.
3. Open the Fuel Valve.
4. Close the Choke Lever.
5. Adjust the Throttle Control to the high speed.
6. Pull the Starter Handle until engine starts.
7. After starting the engine, open the Choke Lever.

AIR FILTER MAINTENANCE

Check air filter daily. Clean the foam pre-filter with warm soapy water. Squeeze out excess water and allow pre-filter to air dry. Apply 1 to 2 ounces of clean engine oil to the foam pre-filter and squeeze out excess. Inspect air filter for damage or excessive dirt. Replace if necessary. Clean all dirt from the inside of the air filter box. Replace air filter and pre-filter every 50 hours of operation or every season.

REF. NO.	DESCRIPTION	PART NO.	QTY
1	Decal Sheet, Engine – 196cc EPA3	A202692	1